

CRANE VALVE GROUP

NOZ-CHEK®

High Performance Check Valves



CRANE

THE VALVE EXPERTS

NON-SLAM CHECK VALVES

NOZ-CHEK®

SCOPE OF LINE

- Sizes 2" – 60"
- ASME B16.34 & API 6D, pressure classes 150 – 4500
- API 6A pressure classes 2000 – 15,000
- Flanged, butt-weld ends, hubs ends and specials
- Standard and short pattern
- Wide range of materials of construction available – consult factory for special application requirements

Noz-Chek is designed and manufactured to the highest quality standards including ISO-9001, Stoomwezen and TUV.

HIGH PERFORMANCE NON-SLAM CHECK VALVE

One of the most significant elements of piping system design is integrating the means to protect mechanical equipment and prevent damage caused by backflow. Backflow prevention is routinely achieved through the use of swing check valves or dual-plate check valves.

Noz-Chek valves are specifically designed for fast-reversing systems where backflow is a constant concern. In such critical service applications, Noz-Chek Non-Slam Check Valves offer the following benefits.

- Minimizes the damaging effects of water hammer in fluid systems
- Removal of chatter associated with conventional valves in reciprocating compressor service
- Protects rotating equipment from damage due to flow reversal
- Minimizes pressure loss in piping systems
- Provides quick dynamic response reducing reverse velocity



INDUSTRY STANDARDS

API 598	Valve Pressure Testing and Inspection
ASME B16.34	Pressure/Temperature Ratings
API 6D	Pipeline Valves
API 6A	Production Valves

FEATURES

Extensive research and development, coupled with valid design procedures, have resulted in these unique Noz-Chek features:

- **Few moving parts** — Disc is the only moving part, minimizing wear.
- **Axial movement of disc** — Disc and seating configuration give streamlined flow path with venturi effect, resulting in low pressure drop.
- **Short stroke of spring-assisted disc** — Inlet flow velocity moves disc axially with short stroke. In response to flow velocity reduction, a compressed spring initiates valve closure and provides quick response.
- **Spring options** — Choice of spring effects critical velocity and valve response. Selection is made on engineering evaluation of specific applications. In absence of this data, a standard spring will be provided.

CHARACTERISTICS

Noz-Chek valves deliver an effective dynamic response under various flow deceleration conditions. The dynamic performance characteristics of Noz-Chek valves are compared to swing check and dual plate spring-assisted check valves in Figure 1.

Noz-Chek’s unique design features result in superior performance, fast response and lower pressure loss in piping systems.

OPENING

Reduced pressure, generated by increased velocity in the minimal flow area results in additional force to assist the disc to open and allows for extra spring loading that facilitates a faster closing time.

This spring force is balanced in the fully open position.

The Noz-Chek geometry is established by considering the design velocity required to ensure that the disc is stabilized open against its stop even if moderate flow oscillation occurs.

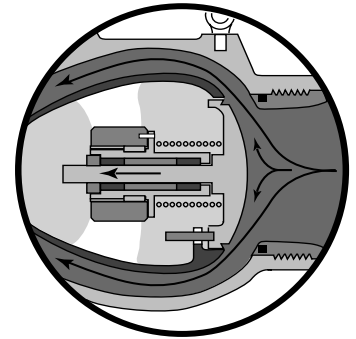

CLOSING

When a noticeable reduction in flow occurs, the disc reacts immediately, limiting backflow and valve slamming:

The spring load, low mass disc, and short displacement ensures a rapid self-dampening response.

For certain applications, the internal geometry can be modified to suit the service conditions.

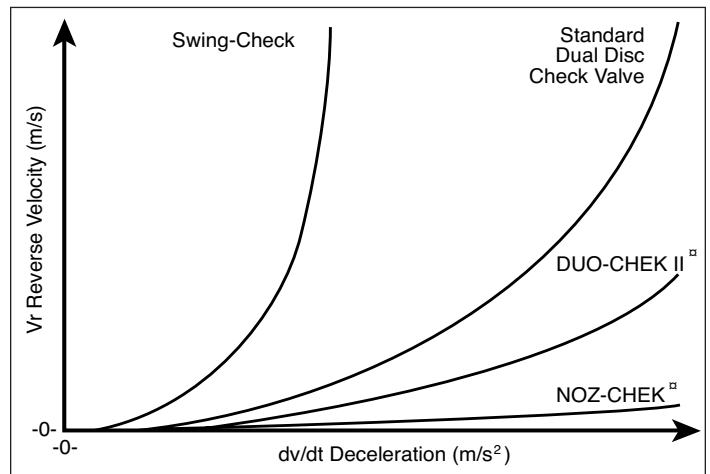
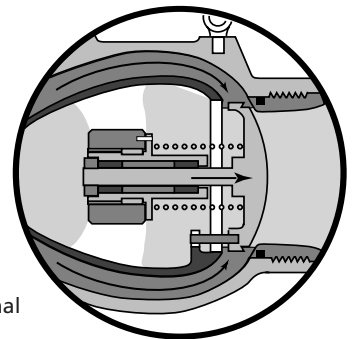

FIGURE 1

TOTAL QUALITY MANAGEMENT

Crane is guided by a commitment to total quality management with a focus in customer satisfaction. Design, manufacturing and testing procedures are certified to ISO 9001, EN 29001, API Q1, API 6D and ASME/ASQC Q91 Quality Assurance. This quality management system is also approved by TUV.

DESIGN

Computer-aided design (CAD) systems at Crane are helpful in developing sound designs. Finite element analysis is utilized to conduct simulated stress analyses for various valve structures to prove design integrity. Flow modeling is applied to optimize pressure drop characteristics. Computer-generated spring designs and disc weight studies have improved the Noz-Chek valve response times.

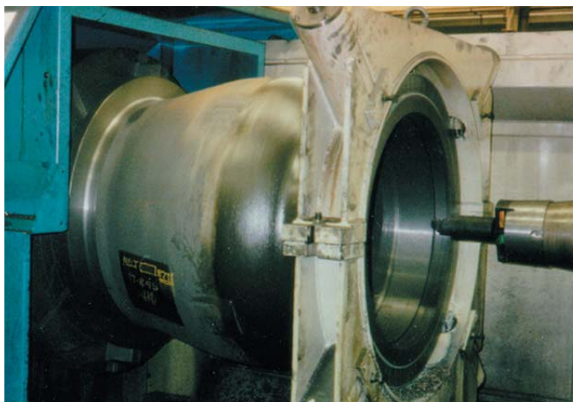
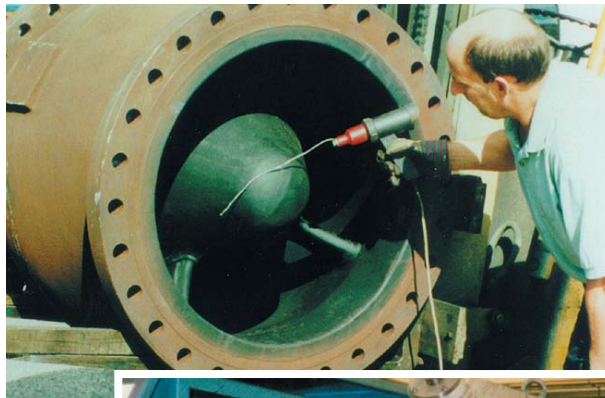

MANUFACTURING CAPABILITIES

Noz-Chek valves can be furnished in sizes from 2" (50mm) to 60" (1500mm), and in pressure classes from ASME Class 150 through 4500 and API ratings from 2000 to 15,000 psi CWP.

A variety of body and trim material is offered, including carbon steel, ductile iron, alloy steels, stainless steel and duplex steel. Coatings may be provided for added corrosion or wear resistance. Hard-facing and weld overlays may also be supplied. Seats may be metal-to-metal or bubble-tight resilient.

TESTING

Inspection and testing are applied throughout the manufacturing process.

- Special nondestructive testing is often specified, which may include radiography, magnetic particle and liquid penetrant.
- Cryogenic and fire tests can be conducted to satisfy customer requirements.
- Each valve is hydrostatically tested to API Standard 598. These tests apply to the body shell and seat, with test duration and leakage rates pertaining to customer requirements. Other test standards are also specified in some cases.

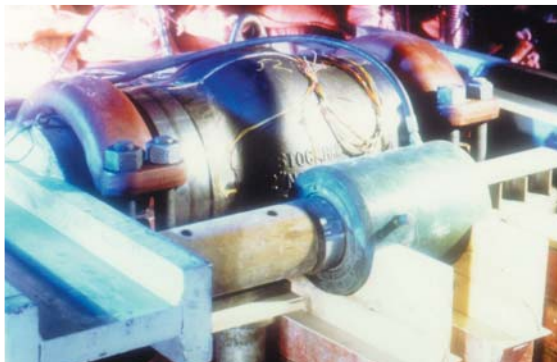
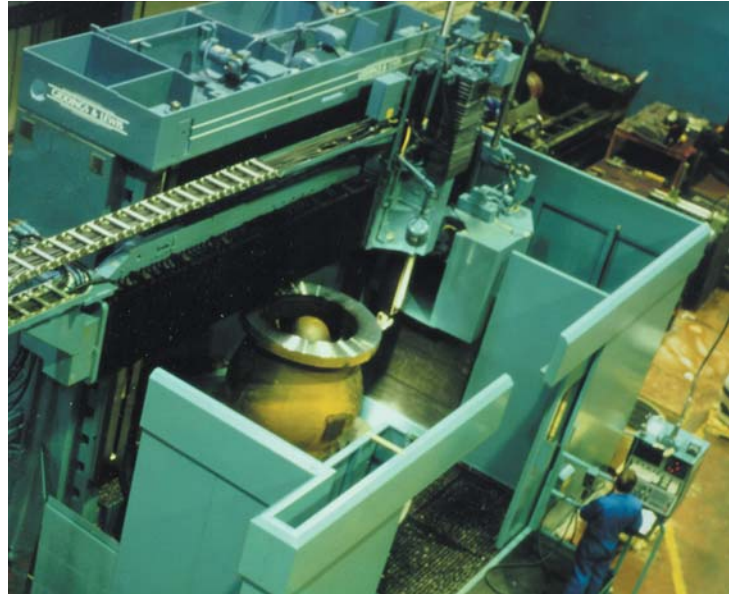

APPLICATIONS

Gas Transmission

- Compressor Suction/Discharge/Bypass

Power Generation

- Feedwater
- Cooling water
- Blowdown
- Steam

Petrochemical / Chemical Processing

- Extreme Units
- Propylene Units

Hydrocarbon Processing

- Catalytic Cracking
- Hydrotreating

Water Transmission

- Pipeline
- Pump Stations

FLOW OUTLET ZONE

Designed for pressure recovery to minimize pressure loss and fluid turbulence resulting in smooth flow.

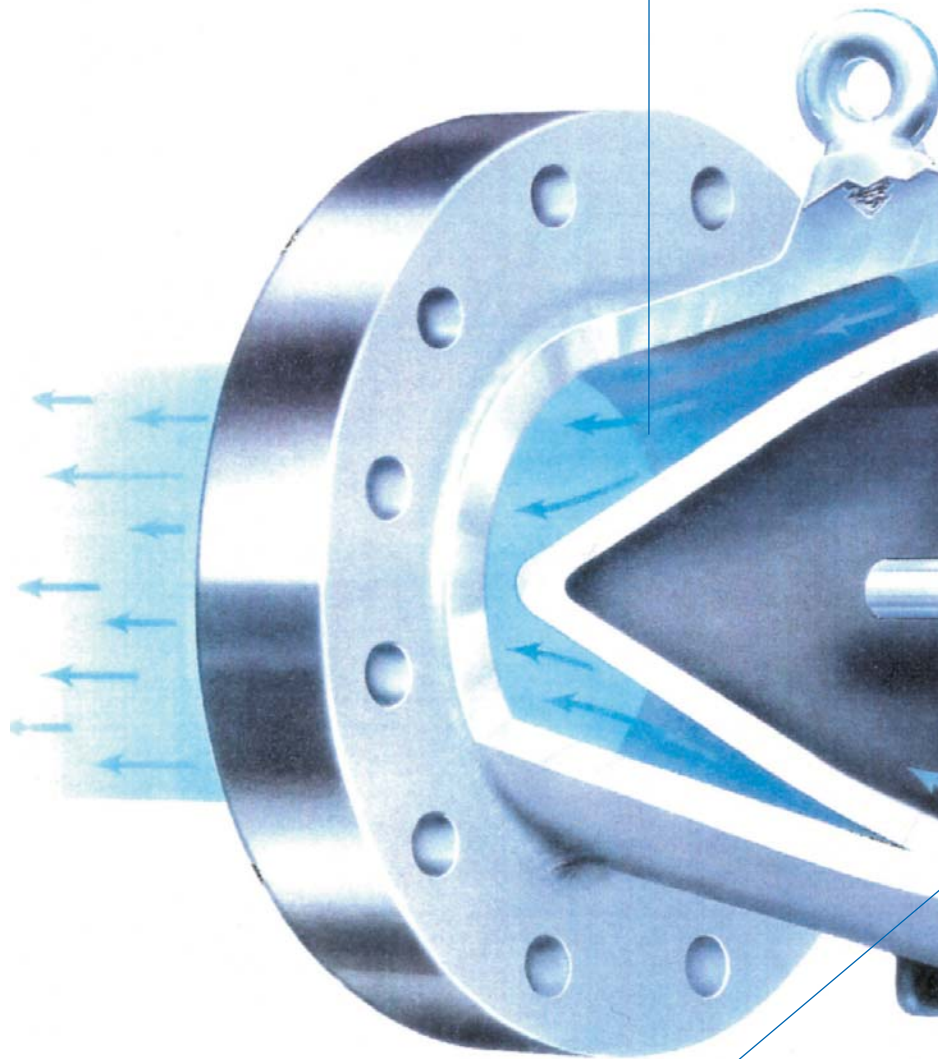

SPRING

As the most strategic component, the spring is designed to meet specific service conditions – a customized approach.

DISC

Standard disc is high strength with minimized weight to provide fast dynamic response. Design minimizes bearing loads, thus lengthens life of bearings and shaft. Offered in a variety of trim materials, with metal or resilient seating.

SEAT

Assures venturi flow by its configuration. Provides seating surface for disc and enables bubble-tight seal with resilient materials.

FLOW INLET ZONE

Venturi design maximizes flow impact on disc. Provides streamlined flow when valve is fully open to minimize pressure loss.

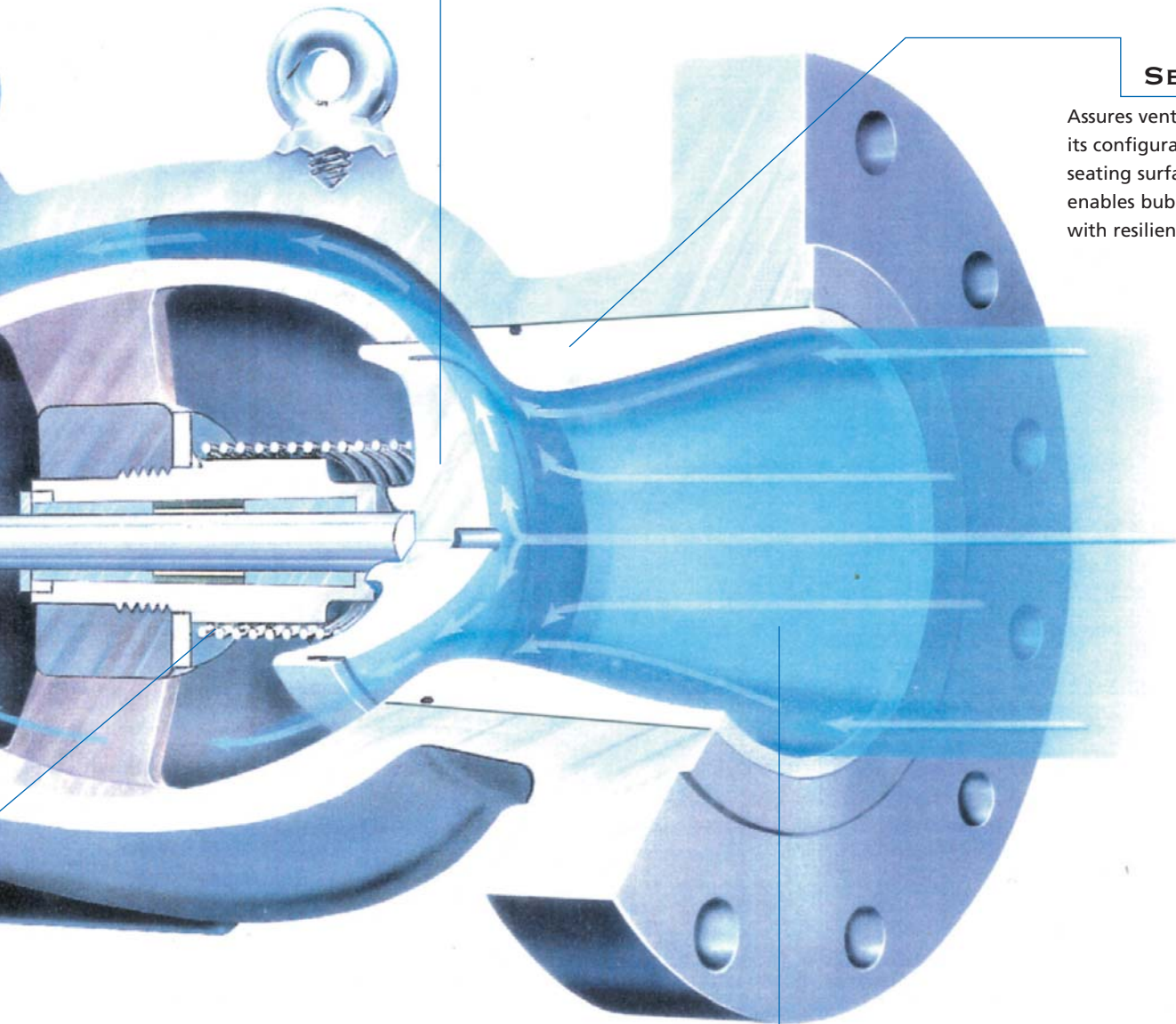

FLANGED END NON-SLAM CHECK VALVE

DIMENSIONAL DATA

Class 150 RF

Nominal Size	Standard Pattern	Short Pattern	Weight	
	A	B	A	B
2	8.00 (203)	-	22 (10)	-
3	9.50 (241)	-	40 (18)	-
4	11.50 (292)	-	80 (36)	-
6	14.00 (356)	-	100 (45)	-
8	19.50 (495)	-	235 (106)	-
10	24.50 (622)	-	465 (209)	-
12	27.50 (699)	-	725 (362)	-
14	31.00 (787)	18.69 (475)	900 (405)	575 (259)
16	34.00 (837)	26.56 (675)	1,470 (662)	970 (437)
18	38.50 (978)	24.00 (610)	1,740 (783)	935 (420)
20	38.50 (978)	33.44 (849)	1,990 (896)	1,450 (653)
24	42.00 (1,067)	31.88 (810)	3,860 (1,737)	2,600 (1,170)
30	60.00 (1,524)	39.75 (1,010)	4,200 (1,890)	2,975 (1,339)
36	77.00 (1,956)	39.37 (1,000)	8,650 (3,893)	6,050 (2,723)
42	78.75 (2,000)	55.69 (1,415)	11,640 (5,238)	9,510 (4,280)
48	88.00 (2,235)	63.56 (1,614)	19,000 (8,550)	14,190 (6,386)
54	100.00 (2,540)	72.81 (1,849)	22,200 (9,990)	18,700 (8,415)
60	114.00 (2,896)	80.13 (2,035)	30,580 (13,761)	25,650 (11,543)

Class 900 RF

Nominal Size	Standard Pattern	Short Pattern	Weight	
	A	B	A	B
2	14.50 (368)	10.44 (265)	77 (35)	65 (29)
3	15.00 (381)	13.00 (330)	122 (55)	113 (51)
4	18.00 (457)	9.56 (243)	220 (99)	167 (75)
6	24.00 (610)	12.24 (311)	430 (194)	325 (146)
8	29.00 (737)	13.63 (346)	810 (365)	625 (281)
10	33.00 (838)	15.38 (391)	1,170 (527)	825 (371)
12	38.00 (965)	17.94 (456)	1,790 (806)	1,200 (540)
14	40.50 (1,029)	19.69 (500)	2,360 (1,062)	1,550 (698)
16	44.50 (1,130)	29.50 (749)	2,390 (1,076)	2,150 (968)
18	48.00 (1,537)	30.50 (775)	3,750 (1,688)	2,680 (1,206)
20	52.00 (1,320)	34.19 (868)	5,110 (2,299)	3,880 (1,746)
24	61.00 (1,549)	40.00 (1,016)	6,730 (3,029)	4,660 (2,079)

Class 300 RF

Nominal Size	Standard Pattern	Short Pattern	Weight	
	A	B	A	B
2	10.50 (267)	-	29 (13)	-
3	12.50 (318)	-	66 (30)	-
4	14.00 (356)	-	105 (47)	-
6	17.50 (445)	10.63 (270)	180 (81)	125 (56)
8	21.00 (533)	12.25 (311)	290 (131)	205 (92)
10	24.50 (622)	12.00 (305)	535 (241)	355 (160)
12	28.00 (711)	17.13 (435)	820 (369)	535 (241)
14	33.00 (838)	18.69 (475)	1,230 (554)	700 (315)
16	34.00 (864)	21.44 (545)	1,600 (720)	905 (407)
18	38.50 (978)	24.00 (610)	1,900 (855)	1,175 (529)
20	40.00 (1,016)	26.56 (675)	2,370 (1,067)	1,800 (810)
24	53.00 (1,346)	31.88 (810)	4,560 (2,052)	2,930 (1,319)
30	62.76 (1,594)	39.75 (1,010)	4,950 (2,228)	3,590 (1,612)
36	82.00 (2,082)	39.37 (1,000)	9,890 (4,451)	5,400 (2,430)
42	78.75 (2,000)	55.69 (1,415)	11,440 (5,140)	9,310 (4,190)
48	88.00 (2,235)	68.56 (1,741)	19,110 (8,560)	14,080 (6,336)
54	100.00 (2,540)	72.81 (1,849)	22,530 (10,139)	19,000 (8,550)
60	114.00 (2,896)	80.13 (2,035)	30,580 (13,761)	25,650 (11,543)

Class 1500 RF

Nominal Size	Standard Pattern	Short Pattern	Weight	
	A	B	A	B
2	14.50 (368)	10.44 (265)	77 (35)	65 (29)
3	18.50 (470)	13.00 (330)	172 (77)	149 (67)
4	21.50 (546)	9.56 (243)	265 (119)	200 (90)
6	27.75 (705)	12.25 (311)	610 (276)	455 (205)
8	32.75 (832)	13.63 (346)	1,210 (546)	810 (365)
10	39.00 (991)	15.50 (394)	2,010 (905)	1,080 (468)
12	44.50 (1,130)	17.94 (456)	3,300 (1,485)	2,020 (909)
14	49.50 (1,257)	19.69 (500)	4,310 (1,940)	2,780 (1,251)
16	54.50 (1,384)	29.50 (749)	4,750 (2,138)	3,230 (1,454)
18	60.50 (1,537)	25.19 (640)	6,350 (2,858)	4,340 (1,953)
20	65.50 (1,664)	34.19 (868)	7,320 (3,294)	5,520 (2,484)
24	76.50 (1,943)	34.19 (868)	12,500 (5,625)	8,800 (3,960)

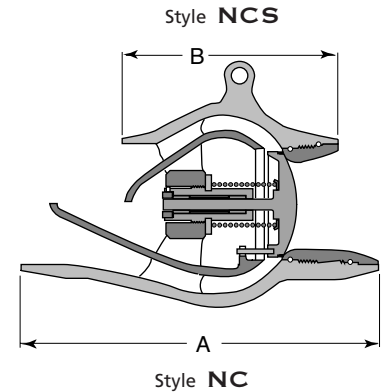

Class 600 RF

Nominal Size	Standard Pattern	Short Pattern	Weight	
	A	B	A	B
2	11.50 (292)	10.44 (265)	37 (17)	32 (14)
3	14.13 (359)	13.00 (330)	68 (31)	58 (26)
4	17.00 (432)	9.56 (243)	155 (70)	120 (54)
6	22.00 (559)	15.38 (391)	290 (131)	240 (108)
8	26.00 (660)	12.25 (311)	500 (225)	360 (162)
10	31.00 (787)	14.38 (365)	870 (392)	600 (270)
12	33.00 (838)	17.25 (438)	1,265 (569)	685 (308)
14	35.00 (889)	18.69 (475)	1,610 (725)	1,010 (455)
16	39.00 (991)	21.44 (545)	2,050 (923)	1,250 (563)
18	43.00 (1,092)	31.88 (810)	2,550 (1,148)	2,200 (990)
20	47.00 (1,194)	31.88 (810)	2,800 (1,260)	2,230 (1,004)
24	55.00 (1,397)	31.88 (810)	4,500 (2,025)	3,330 (1,499)
30	65.00 (1,651)	39.75 (1,010)	7,800 (3,510)	5,700 (2,565)
36	82.00 (2,083)	47.81 (1,214)	18,040 (8,118)	11,400 (5,130)

Class 2500 RF

Nominal Size	Standard Pattern	Short Pattern	Weight	
	A	B	A	B
2	17.75 (451)	13.00 (330)	112 (50)	95 (43)
3	22.75 (578)	13.00 (330)	245 (110)	210 (95)
4	26.50 (673)	12.19 (310)	370 (167)	290 (131)
6	36.00 (914)	15.86 (403)	1,080 (486)	800 (360)
8	40.25 (1,022)	17.69 (449)	1,432 (644)	1,100 (495)
10	50.00 (1,270)	22.13 (562)	3,285 (1,487)	2,130 (959)
12	56.00 (1,422)	36.00 (914)	3,898 (1,754)	3,200 (1,440)

ASME B16.34 FOR STEEL AND 316 STAINLESS STEEL MATERIALS

Temperature		Maximum Non-Shock Service Pressure, psi and kg/cm ² (ASME B16.34)											
°C	°F	Series 150				Series 300				Series 600			
		Steel ¹		316SS		Steel ¹		316SS		Steel ¹		316SS	
		kg/cm ²	psi	kg/cm ²	psi	kg/cm ²	psi	kg/cm ²	psi	kg/cm ²	psi	kg/cm ²	psi
-29 to 38	-20 to 100	20.0	285	19.3	275	52.0	740	50.6	720	104.0	1480	101.2	1440
66	150	19.0	270	17.9	255	49.6	705	47.1	670	99.1	1410	94.2	1340
93	200	18.3	260	16.9	240	47.5	675	43.6	620	94.9	1350	87.2	1240
121	250	17.2	245	15.8	225	46.7	665	41.5	590	93.5	1330	83.0	1180
149	300	16.2	230	15.1	215	46.0	655	39.4	560	92.4	1315	78.7	1120
177	350	15.1	215	14.4	205	45.3	645	37.6	535	90.7	1290	75.6	1075
204	400	14.1	200	13.7	195	44.6	635	36.2	515	89.3	1270	72.4	1030
232	450	13.0	185	12.7	180	43.2	615	34.8	495	86.8	1235	69.6	990
260	500	12.0	170	12.0	170	42.2	600	33.7	480	84.4	1200	67.1	955
288	550	10.9	155	10.9	155	40.4	575	32.7	465	80.5	1145	65.4	930
316	600	9.8	140	9.8	140	38.7	550	31.6	450	77.0	1095	63.6	905
343	650	8.8	125	8.8	125	37.6	535	31.3	445	75.6	1075	62.6	890
371	700	7.7	110	7.7	110	37.6	535	30.2	430	74.9	1065	60.8	865
399	750	6.7	95	6.7	95	35.5	505	29.9	425	71.0	1010	59.4	845
427	800	5.6	80	5.6	80	28.8	410	29.2	415	58.0	825	58.3	830
454	850	4.4	65	4.6	65	19.0	270	28.5	405	37.6	535	56.9	810
468	875	3.9	55	3.9	55	15.5	220	28.1	400	30.9	440	56.2	800
482	900	3.5	50	3.5	50	12.0	170	27.8	395	24.3	345	55.5	790
496	925	2.8	40	2.8	40	9.5	135	27.4	390	19.3	275	54.8	780
510	950	2.5	35	2.5	35	7.4	105	27.1	385	14.4	205	54.5	775
524	975	1.8	25	1.8	25	5.3	75	26.4	375	10.9	155	52.7	750
538	1000	1.4	20	1.4	20	3.5	50	25.7	365	7.4	105	51.0	725
Hydrostatic Shell Test		31.6	450	29.9	425	79.1	1125	77.3	1100	156.4	2225	152.9	2175

Temperature		Maximum Non-Shock Service Pressure, psi and kg/cm ² (ASME B16.34)											
°C	°F	Series 900				Series 1500				Series 2500			
		Steel ¹		316SS		Steel ¹		316SS		Steel ¹		316SS	
		kg/cm ²	psi	kg/cm ²	psi	kg/cm ²	psi	kg/cm ²	psi	kg/cm ²	psi	kg/cm ²	psi
-29 to 38	-20 to 100	156.1	2220	151.8	2160	260.5	3705	253.1	3600	433.8	6170	421.8	6000
66	150	149.0	2120	141.3	2010	248.9	3540	235.2	3345	414.4	5895	392.3	5580
93	200	142.4	2025	130.8	1860	237.3	3375	217.6	3095	395.4	5625	362.7	5160
121	250	140.2	1995	124.4	1770	233.7	3325	207.0	2945	398.8	5545	345.2	4910
149	300	138.5	1970	118.1	1680	230.6	3280	196.5	2795	384.5	5470	327.6	4660
177	350	136.0	1935	113.2	1610	226.7	3225	188.4	2680	377.9	5375	314.2	4470
204	400	133.6	1900	108.3	1540	222.9	3170	180.7	2570	371.2	5280	300.9	4280
232	450	129.7	1845	104.4	1485	216.5	3080	174.3	2480	361.0	5135	290.3	4130
260	500	126.2	1795	100.9	1435	210.5	2995	168.0	2390	350.8	4990	279.8	3980
288	550	120.6	1715	98.1	1395	201.4	2865	163.1	2320	346.2	4925	272.1	3870
316	600	115.3	1640	95.3	1355	192.3	2735	158.5	2255	320.6	4560	264.3	3760
343	650	113.2	1610	93.5	1330	188.8	2685	156.1	2220	314.6	4475	260.1	3700
371	700	112.5	1600	91.0	1295	187.3	2665	151.8	2160	312.1	4440	253.1	3600
399	750	106.2	1510	89.3	1270	177.2	2520	148.3	2110	295.3	4200	247.5	3520
427	800	86.8	1235	87.5	1245	144.8	2060	145.9	2075	241.1	3430	243.2	3460
454	850	56.6	805	85.4	1215	94.2	1340	142.7	2030	156.8	2230	233.4	3320
468	875	46.4	660	84.0	1195	77.3	1100	140.6	2000	128.6	1830	232.0	3300
482	900	36.2	515	83.0	1180	60.5	860	138.5	1970	100.5	1430	230.6	3280
496	925	28.8	410	82.3	1170	48.2	685	137.1	1950	80.5	1145	228.5	3250
510	950	21.8	310	81.5	1160	36.2	515	135.7	1930	60.5	860	226.4	3220
524	975	16.2	230	79.1	1125	27.1	385	131.8	1875	45.3	645	219.7	3125
538	1000	10.9	155	76.6	1090	18.3	260	127.9	1820	30.2	430	213.0	3030
Hydrostatic Shell Test		235.5	3350	228.5	3250	391.9	5575	379.6	5400	652.0	9275	632.7	9000

¹Permissible, but not recommended for prolonged use above 800°F (427°C)

ORDERING INFORMATION

NOZ-CHEK®

24"

Valve Size

NC

Style

30

Pressure Class

S

Body & Trim

M

Seal

F

End Connection

Modification Number

Description: 24" Style NC, ASME Class 300, Carbon Steel Body, Buna-N Seal, Raised Face Flanges (No Modifications)

VALVE SIZE

Nominal valve sizes are expressed in inches, for ASME, API and BS flange standards or millimeters for DIN, AS and JIS flange standards. (Size preceded by "M" for DIN, "A" for AS or "J" for JIS)

STYLE

ORDERING LETTER	BODY STYLE	SIZE RANGE
NC	Integral Body, Standard Pattern	2" through 60" (50mm through 1500mm)
NCS	Integral Body, Short Body Pattern	2" through 60" (50mm through 1500mm)

SEAL

Operating temperature for general guidance only

CODE LETTER	SEAL MATERIAL	OPERATING TEMP. °C	OPERATING TEMP. °F
M	Buna-N	-57 to 120	-70 to 250
V	Viton-B®	-40 to 204	-40 to 400
P	Metal	-257 to 537	-450 to 1000
T	PTFE	-196 to 204	-328 to 400
Z	EPDM*	-57 to 120	-70 to 250

©Viton Registered Trade Mark E.I. Dupont. Metal seats may be furnished as integral or special overlay materials are available.

* Approved for drinking water.

FLANGE SERIES

(ASME B16.42 Series "A" or "B" to be specified over 24")

ASME		API		DIN/JIS		BS/AS	
ORDERING NO.	PRESSURE CLASS	ORDERING NO.	RATING	ORDERING NO.	PN RATING	ORDERING NO.	TABLE
15	150	21	2000	Flange Standard: M-DIN J-JIS	6 thru 320	B-BS	A
30	300	31	3000			A-AS	thru
60	600	51	5000				T
90	900	101	10,000				
150	1500	151	15,000				
250	2500						
450	4500						

STANDARD BODY & DISC MATERIALS

CODE	BODY	DISC
S	ASTM A 216 GR WCB carbon steel	alloy steel
C	ASTM A 351 GR CF8M 316 stainless steel	stainless steel
E	ASTM A 217 GR CA15 410 stainless steel	11-13 chrome
DD	BS EN 1563 GR EN-GJS-450-10** ductile iron	stainless steel
GC	ASTM A 352 GR LCC low temp. carbon steel	alloy steel
DZ	ASTM A890 GR 4A duplex stainless steel	Duplex SS

**also available in ASTM A 395a

MODIFICATIONS

A modification number is assigned when non-standard features, material mixes or documentation are ordered.

END CONNECTIONS

ORDERING LETTER	CONNECTIONS
F	Flanged-Raised Face
G	Grayloc® End
P	Flanged Smooth Finish
R	Flanged Ring Joint
W	Butt Weld

®Grayloc Registered Trademark Gray Tool Co.

SPRING MATERIAL

SPRING MATERIAL	MAXIMUM RECOMMENDED OPERATING TEMPERATURES	
	C°	F°
316 Stainless Steel	120	250
Inconel 600®	315	600
Inconel X-750®	537	1000

®Inconel Registered Trademark International Nickel Co. For temperatures up to 600°F (315°C), Inconel will be furnished as standard. For service temperatures above 600°F (315°C), Inconel X-750 springs will be specified. Other alloy spring materials are available to meet specific service requirements.

DUO-CHEK

HIGH PERFORMANCE WAFER AND LUG CHECK VALVES

- Designed to meet ASME, BS and API standards
- Sizes 2 through 72 inches

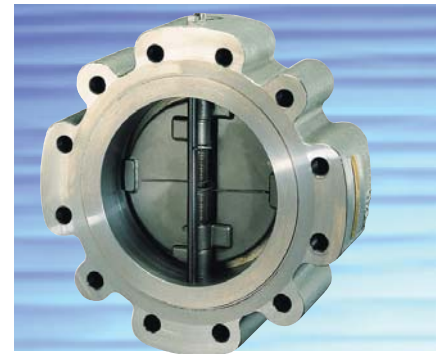

NOZ-CHEK®

**BELFAST,
NORTHERN IRELAND OPERATIONS**

6 Alexander Road
Cregagh, Belfast BT6 9HJ
Tel: +44(0) 28 90 70 4222
Fax: +44(0) 28 90 40 1582

Craig Sienerth

National Sales Manager (USA)
Crane Stockham Valve
7606 Grand Terrace Court
Houston, TX 77095
Tel: 832 593 7203
Fax: 832 593 7204

**THOMASTOWN,
AUSTRALIA OPERATIONS**

322 Settlement Road
Thomastown, VIC 3074
Tel: 61-39-465-2755 • Fax: 61-39-466-1365

**CONROE,
TEXAS OPERATIONS**

9860 Johnson Road
Montgomery, Texas 77316-9494
Tel: 936-588-4447 • Fax: 936-588-4427

CRANE VALVE GROUP

Flow Control on a Global Scale

CENTER LINE

Resilient Seated Butterfly and Check Valves
Pneumatic and Electric Actuators

FLOWSEAL

High Performance Butterfly Valves

DUO-CHEK & MARLIN

High Performance Wafer Check Valves

NOZ-CHEK & COMPAC NOZ

Severe Service Check Valves

PACIFIC

High Pressure and Severe Service Valves
Quarter Turn Severe Service Plug Valves

CRANE NUCLEAR, INC.

Valves Designed for Nuclear Service
Diagnostic Valve Repair, Equipment and Services

CRANE

Cast Steel, Bronze, Iron and Alloy Valves

JENKINS

Bronze, Iron, Cast Steel, and Alloy Valves

ALOYCO

Corrosion Resistant Gate, Globe and Check Valves

CRANE SERVICE CENTERS

Certified OEM Valve Repair Services

CRANE

THE VALVE EXPERTS

VISIT OUR WEBSITE FOR OUR FEATURED PRODUCTS.

www.cranestockham.co.uk